

# Installation Instructions

Natural Light  
Solar Attic Fan

2640 East Rose Garden Lane, Suite 6 • Phoenix, AZ 85050 • 800-363-9865  
www.solaratticfan.com

## IMPORTANT: Before Installing

Please take the time to read through the ENTIRE instructions prior to starting any work.

## Precautions

1. Ensure normal safety precautions are taken when using tools and walking on roofs.
2. Do not cut any structural members in the house.
3. Measure twice and cut once.

## Components

**Note:** Exploded view for illustrative purposes.  
Unit comes pre-assembled.

1. (2) #8 x 1" Self-Tapping Screws
2. Custom Solar Panel
3. Wire Lead
4. Adjustable Solar Panel Bracket
5. Aluminum Shroud
6. Air Drive Precision Pitch Blade
7. Motor Isolation Bracket
8. Custom DC Motor
9. 4" x 48" Stainless Steel Wire Mesh
10. Rugged 14 Gauge Shroud Support Bracket
11. (6) #6 x 1 1/2" Stainless Steel Phillips Head Screws
12. Aluminum Flashing

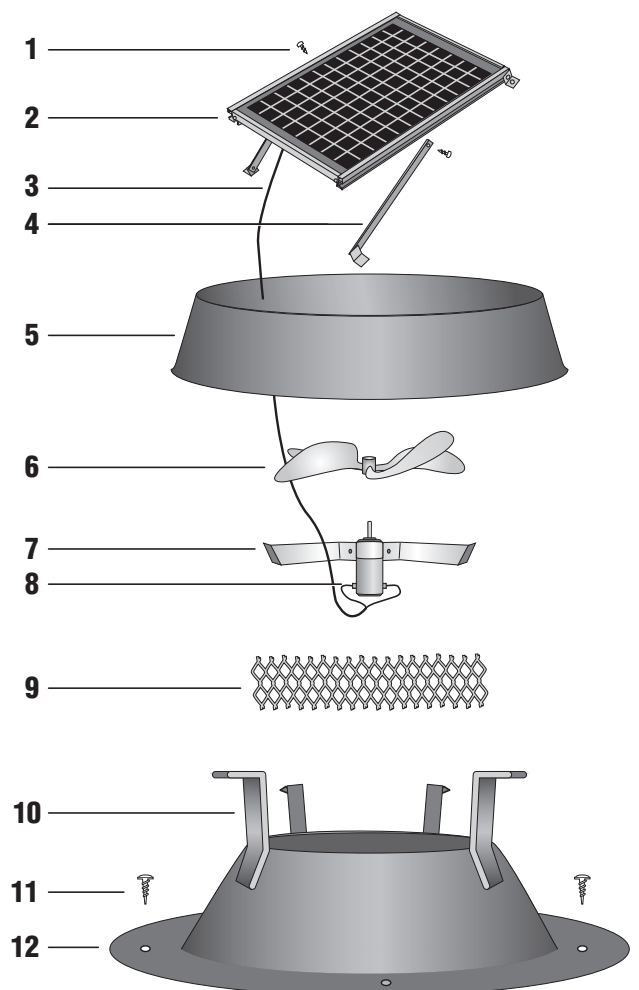

## Tools Required

- Reciprocating Saw
- Marking Pen
- String
- Caulking Gun
- Screw Gun
- Ladders
- Measuring Tape
- Razor Knife

## Installation Pointers

- When determining location of the unit, try to place the solar attic fan on the south side of the roof, also consider potential problems such as objects shading the unit during certain times of the day.
- Make 14" circular template for the hole that needs to be cut on the roof. Use the outer circumference of the flashing hole for sizing.

### Step 1

Choose location for solar vent unit, south exposure is best. If a southern exposure is not feasible for your installation, the fan can be installed on any other exposure and the solar panel adjusted to capture maximum sunlight. The solar attic fan must be installed between roof rafters.

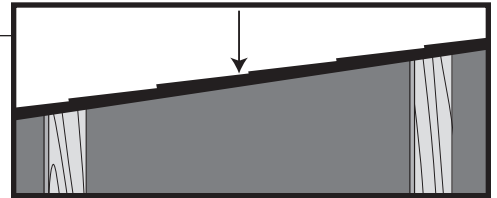

### Step 2

Hammer a nail at the center of the location chosen between rafters for the solar attic fan unit. Attach a string to the nail. Measure 7" of string and attach a marking pen to the string, **see diagram**. Scribe a 14" circle onto the roof shingles or use the template created earlier.

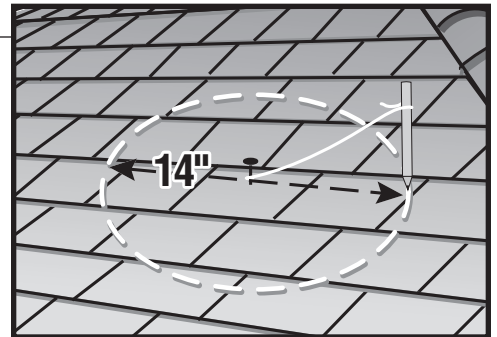

### Step 3

**IMPORTANT:** The solar attic fan must be installed between the roof rafters. **DO NOT CUT THROUGH ANY FRAMING MEMBER.**

With a reciprocating saw, cut the diameter of the hole.

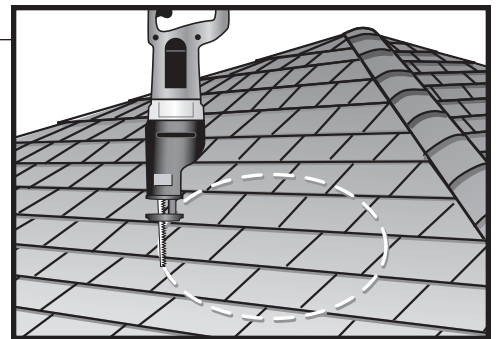

### Step 4

With a razor knife, cut a four inch slit through the shingles and tar paper at the three and nine o'clock position of the flashing. This allows for the foot print of the flashing to be inserted under the shingles.

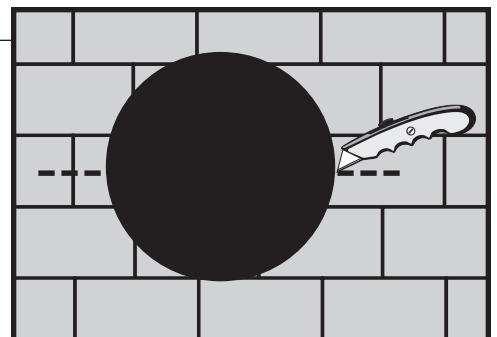

## Step 5

Insert the reciprocating saw blade sideways at the three o'clock position and commence cutting the roofing nails up and around to the nine o'clock position. This process removes the nails that will prevent the flashing foot print from sliding up underneath the shingles.

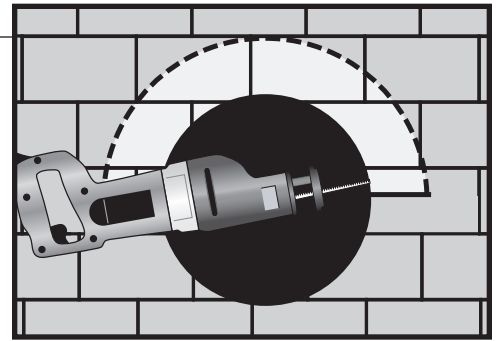

## Step 6

Caulk **underside** of flashing with the provided caulking material. Two concentric rings of caulking material is sufficient.

**NOTE:** Installation on tile roofs will require the use of a skirt.

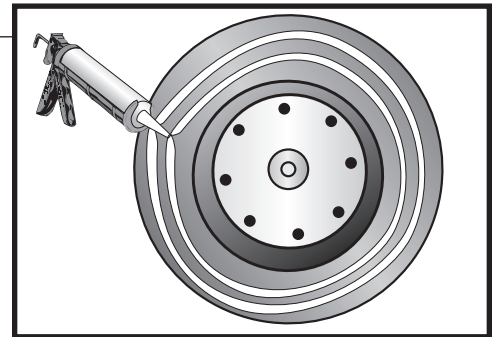

## Step 7

Taking care not to smear caulk on the exposed shingles, slide flashing under tar paper and shingles and force flashing up until the shingles come in contact with the raised portion of the flashing. The bottom side of the flashing will be on top of the shingles. Secure flashing with four Phillips head screws at the 3:00, 6:00, 9:00 and 12:00 positions. The 3:00 and 9:00 positions screws should go under the shingles. The 6:00 and 12:00 position screws should go on top of the shingles.

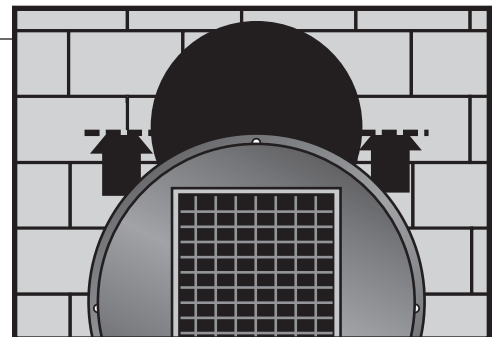

## Step 8

At the 6:00 and 12:00 positions, caulk over the screw head, since it will be exposed to the weather. Use remaining caulk to seal the areas where the 4" slits were made and around the area where the shingles meet with the raised area of the flashing.

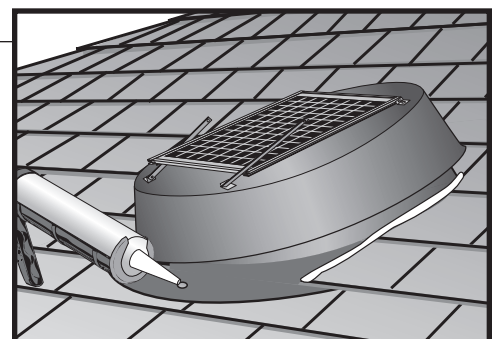

## Step 9

Adjust the solar panel to the position it will collect the most sunlight throughout the day. Using the two self-tapping screws provided, screw the adjustable brackets to the side of the solar panel frame making sure the screws do not damage the panel.

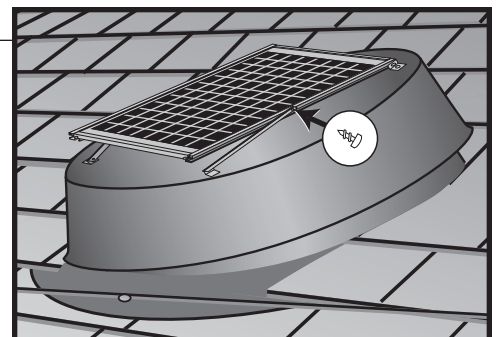



WARRANTY

This Natural Light Solar Attic Fan has a 25 year warranty on the housing, 10 year warranty on the solar panel and a 5 year warranty on the motor.

IMPORTANT: PLEASE COMPLETE AND MAIL THE CARD BELOW AS SOON AS YOUR SOLAR ATTIC FAN IS INSTALLED. This card will serve as proof of your purchase, should you misplace your original invoice.

The manufacturer warrants this product to be free from defects in material and manufacturer's workmanship for a period of five years on the motor, 10 years on the solar panel, and 25 years on the housing, from the date of installation. This warranty is subject to proper installation of the unit in accordance with the manufacturer's written installation instructions. The manufacturer will not be liable for any special, incidental or consequential damages in any way related to, or arising out of, defects in, or damage to, the solar attic fan.

This warranty gives you specific legal rights, and you may have other rights which vary from state to state concerning exclusion or limitation of incidental or consequential damages.

Natural Light Tubular Skylights • 2640 E. Rose Garden Lane #6 • Phoenix, AZ 85050

REGISTRATION

Natural Light Solar Attic Fan Installer: \_\_\_\_\_

Date of Purchase: \_\_\_\_\_

Customer Name: \_\_\_\_\_

Address: \_\_\_\_\_

City: \_\_\_\_\_ State: \_\_\_\_\_ Zip: \_\_\_\_\_

Customer Survey

Are you satisfied with the performance? Y N

What made you choose our product? \_\_\_\_\_

Were you satisfied with the installation job? \_\_\_\_\_

Comments: \_\_\_\_\_